

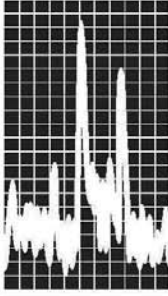

**AT5010/ 5011/ 5000**  
 **SPECTRUM**  
**ANALYZERS**  
**Operating Instructions**

The section header consists of the model numbers "AT5010/ 5011/ 5000" in a large, bold, black font. Below this is a graphic of a spectrum analyzer waveform, which is a white line with several peaks and valleys, plotted against a black grid. To the right of the waveform, the words "SPECTRUM" and "ANALYZERS" are stacked vertically in a very large, bold, black font. At the bottom of this section, the words "Operating Instructions" are written in a white, sans-serif font on a solid black rectangular background.

**MADELL TECHNOLOGY CORPORATION**

© 2004 COPYRIGHT

<http://www.madelltech.com>

---

# Contents

<b>Spectrum Analyzers</b> .....	<b>2</b>
Near Field Sniffer Probes AZ530 .....	3
Frequency Expander AT5000F Series .....	4
AT808 GSM Servicing RF Signal Generator ...	4
<b>General Information</b> .....	<b>5</b>
Symbols .....	5
Tilt handle .....	5
<b>Safety</b> .....	<b>6</b>
Operating conditions .....	7
Warranty .....	7
Maintenance .....	7
Switching over the mains/line voltage .....	7
<b>Introduction</b> .....	<b>8</b>
Operating Instructions .....	9
Control Elements .....	9
Vertical Calibration .....	11
Horizontal Calibration .....	12
<b>Introduction to Spectrum Analysis</b> ...	<b>13</b>
Types of Spectrum Analyzers .....	13
Spectrum Analyzer Requirements .....	14
Frequency Measurements .....	14
Resolution .....	15
Sensitivity .....	15
Video Filtering .....	16
Spectrum Analyzer Sensitivity .....	16
Frequency Response .....	17
Tracking Generators .....	17
<b>Mainly Performance and Calibration</b> ...	<b>18</b>
<b>Block Diagram AT5010/11</b> .....	<b>19</b>
<b>Front View AT5010</b> .....	<b>20</b>
<b>Front View AT5011</b> .....	<b>21</b>
<b>Front View AT5000</b> .....	<b>22</b>

## Spectrum Analyzer AT5010/5011/5000



AT5010

- **Frequency Range:** 0.15MHz to 1050MHz
- **4½ Digit Display** (Center & Marker Frequency, 0.1MHz resolution)
- **-100 to +13dBm Amplitude Range**, 20KHz, 400KHz and Video-Filter
- **Tracking-Generator** (AT5011 only)
- **Frequency range:** 0.15MHz to 1050MHz
- **Output Voltage:** +1dBm to 50dBm(50Ω)
- **Accessories:** Users Manual, Power Cord 1pcs

Evolution of the original AT5005/AT5006 has led to the new AT5010/5011 Spectrum Analyzer/Tracking Generator which now extends operation over 1GHz (frequency range 0.15 to 1050MHz). Both fine and coarse center frequency controls, combined with a scan width selector provide simple frequency domain measurements from 100KHz/Div. To 100 MHz/Div. Both models include a 4½ digit numeric LED readout that can selectively display either the center or marker frequency. The At5011 includes a tracking generator. The AT5010/5011 offer the same operation modes as the AT5005/5006. The instruments are suitable for pre-compliance testing during develop. prior to third party testing. A near-field sniffer probe set, AZ530, can be used to locate cable and PC board emission "hot spots" and evaluate EMC problems at the breadboard and prototype level. The combination of AT5010/5011 with the AZ530 is an excellent solution for RF leakage/radiation detection, CATV/MATV system troubleshooting, cellular telephone/pocket pager test, and EMC diagnostics. There is an optional measurement output for a PC which makes documentation of results easy and affordable with the AO500 interface.

## Applications

- AT spectrum analyzer can carry out good inspection to the faults of cable system and wireless system including remote control, cordless phone, cable TV and communication equipment, as well as good comparison and analysis to frequency of signals.
- AT5010 spectrum analyzer can test mobile phone, RF circuits, for example, control signal of logic circuit, baseband signal; local oscillator signal of RF circuit, IF signal and transmission signal, It is very quick and accurate to use AT5010 spectrum analyzer to overhaul the fault of mobile phone which can not enter the network, and determine the fault point.
- **Electromagnetic Compatible (EMC) Testing:** measure the function of harmful electromagnetic wave to be transmitted by various electronic equipments. In addition, it can output AM/FM demodulation signal from socket PHONE, identify the broadcast signal affected by noise. From authorization aspect, it is very effective measurement function for the evaluation and research in advance to carry out the measurement of radioactive noise.
- Widely used for production, development, education and scientific research. True form of signal (such as RF pulse signal) can be observed from ATTEN spectrum analyzer clearly, where figures are expanded by Fourier series, good for apprehend in education and research.

## Specifications

- **Frequency range:** 0.15MHz to 1050MHz
- **Center frequency display accuracy:** ±100KHz
- **Marker accuracy:** ±(0.1% span+100KHz)
- **Frequency display res.:** 100KHz (4½ digit LED)
- **Frequency scan width accuracy:** ±10%
- **Frequency stability:** better than 150KHz/hour
- **Resolution:** 400KHz and 20KHz
- **Video-Filter on:** 4KHz
- **Sweep rate:** 43Hz
- **Amplitude range:** -100dBm to +13dBm
- **Screen display range:** 80dB (10dB/div)
- **Reference level:** -27dBm to +13dBm (in 10dB steps)
- **Reference level accuracy:** ±2dB
- **Average noise level:** -99dBm (20KHz BW)
- **Distortion:** < -55dBc: 2nd and 3rd harmonic  
3rd order intermod: -70dBc

(two signals >3MHz apart)

- **Sensitivity:** Better than -90dBm
- **Log scale fidelity:**  $\pm 2\text{dB}$  (without attn.)  
Ref: 250MHz
- **Input attenuator:** 0 to 40dB (4 $\times$ 10dB steps)
- **Input attenuator accuracy:**  $\pm 1\text{dB}/10\text{dB}$  step
- **Max. input level:** +10dBm,  $\pm 25\text{VDC}$  (0dB attenuation) +20dBm (40dB attenuation)
- **Frequency scan width:** 100KHz/div. to 100MHz/div. in 1-2-5 steps and 0Hz/div. (Zero Scan)

## Tracking Generator

- **Output Frequency:** 0.15 MHz to 1050 MHz
- **Output attenuator:** 0 to 40dB (4 $\times$ 10dB steps)
- **Output attenuator accuracy:**  $\pm 1\text{dB}$
- **Frequency response:**  $\pm 1.5\text{dB}$
- **Output impedance:** 50  $\Omega$  (BNC)
- **Radio Frequency Interference (RFI):** <20dBc
- **Output level range:** -50dBm to +1dBm  
(in 10dB steps and var.)

## General Specifications

- **Display:** 6 inch, 8 $\times$ 10 division graticule
- **Trace rotation:** adjustment from front panel
- **Power:** 220V  $\pm 10\%$ , 50Hz to 60Hz
- **Power consumption:** approx. 20W
- **Operation Ambient:** 0 $^{\circ}\text{C}$  to +40 $^{\circ}\text{C}$
- **Safety:** Grade I (IEC 1010-1)
- **Weight:** approx. 7kg
- **Dimensions:** 380 $\times$ 285 $\times$ 125 (L $\times$ W $\times$ H) mm
- **Input impedance:** 50  $\Omega$
- **Socket:** BNC
- **Load resistance:** > 8  $\Omega$
- **AM/FM demodulation output**

## Near Field Sniffer Probes AZ530 (Optional)

The AZ530 is the ideal toolkit for the investigation of RF electromagnetic fields. It is indispensable of EMI pre-compliance testing during product development, prior to third party testing. The set includes 3 hand-held probes with a built-in pre-amplifier covering the frequency range from 100KHz to over 1000MHz.

The probes-ove magnetic field probe, one electric field probe, and one high impedance probe are all matched to the 50  $\Omega$  inputs of Spectrum analyzers or RF-receivers. The power can be supplied either

from batteries, Ni-Cads or through a power cord directly connected to an AT5010/AT5011 series spectrum analyzer.

Signal feeds via a 1.5m BNC-cable. When used in conjunction with a spectrum analyzer or measuring receiver, the probes can be used to locate and qualify EMI sources, as well as evaluate EMC problems at the breadboard and prototype level. They enable the user to evaluate radiated fields and perform shield effectiveness comparisons. Mechanical screening performance and immunity tests on cables and components are easily performed.

## Specifications

- **Frequency range:** 0.1MHz to 1000MHz  
(lower frequency limit depends on probe type)
- **Output impedance:** 50  $\Omega$
- **Output connector:** BNC
- **Input capacitance:** 2pF (high imped Probe)
- **Max. Input Level:** +10dBm  
(without destruction)
- **1dB-compression point:** -2dBm  
(frequency range dependent)
- **DC-input voltage:** 20V max
- **Supply Voltage:** 6V DC, 4AA size batteries, Supply-power of Analyzer
- **Supply Current:** 8mA (H-Field Probe), 5mA (E-Fieldprobe), 24mA (High imp probe)
- **Probe Dimensions:** 195 $\times$ 40 $\times$ 19 (L $\times$ W $\times$ H)mm
- **Housing:** Plastic (electrically shielded internally)

## The H-Field Near-Field probe

The H-Field probe provides a voltage to the connected measurement system which is proportional to the magnetic radio frequency (RF) field strength existing at the probe location. With this probe, circuit RF sources



AZ530-M

may be localized in close proximity of each other. The H-Field will decrease as the cube of the distance from the source, A doubling of the distance will reduce the H-field by a factor of eight ( $H=1/d^3$ ), where d is the distance.

In the actual use of the H-field sensor one observes therefore a rapid increase of the probe's output voltage as the interference source is approached. While investigating a circuit board, the sources are



immediately obvious. It is easily noticed which component (i.e. IC) causes interference and which does not. In addition, by use of a spectrum analyzer the maximum amplitude as a function of frequency is easily identified. Therefore, one can eliminate early in the development components which are not suitable for EMC purposes. The effectiveness of countermeasures can be judged easily. One can investigate shields for "leaking" areas and cables or wires for conducted interference.

## The E-Field Monopole Probe

The E-field monopole probe has the highest sensitivity of the three probes. It is sensitive enough to be used as an antenna for radio or TV reception. With this probe the entire radiation from a circuit or an equipment can be measured.



AZ530-E

It is used, for example, to determine the effectiveness of shielding measures. With this probe, the entire effectiveness of filters can be measured by measuring the RFI which is conducted along cables that leave the equipment and may influence the total radiation. In addition, the E-field probe may be used to perform relative measurements for certification tests. This makes it possible to apply remedial suppression measures so that any re-qualification results will be positive. In addition, pre-testing for certification tests may be performed so that no surprises are encountered during the certification tests.

## The High-Impedance probe

The High-impedance probe (Hi-Z) permits the determination of the radio frequency interference (RFI) on individual contacts or printed circuit traces. It is a direct-contact probe. The probe is of very high impedance (*near the insulation resistance of the printed circuit material*) and is loading the test point with only 2pF (80 Ω at 1GHz). Thereby one can measure directly in a circuit without significantly influencing the



AZ530-H

relationships in the circuit with the probe. One can, for example, measure the quantitative effectiveness of filters or other blocking measures. Individual pins of ICs can be identified. With this Hi-Z probe individual test points of a circuit can be connected to the 50Ω impedance of spectrum analyzer.

## Frequency Expander AT5000F Series (Optional)

Since the prices of 3GHz spectrum analyzers are all above several ten thousands RMB, it is not affordable for most radio fans, service men and even medium or small sized enterprises. Meantime, there are many signals above 1000MHz in communication field, such as LO (local oscillator) signals of mobile phone usually between 1GHz to 2GHz, some are exceed 2GHz, and 1800MHz, 2400MHz or more. Based on above situations, favorable frequency expanders have been developed by Shenzhen ATTEN Electronics Co., Ltd.

- AT5000F1 operating accompany with AT5000 series spectrum analyzer of 1000MHz, frequency can be expanded to 1050MHz to 2050MHz. Example: connect AT5000F1 to AT5010 spectrum analyzer, if a 800MHz signal display in spectrum analyzer, then the tested signal should be added 100MHz, so the frequency of tested signal must be 1800MHz.
- Frequency of AT5000F2 can be expanded to 2050MHz to 3050MHz, the tested frequency is the display frequency add 2000MHz.
- Frequency of AT5000F3 can be expanded to 3050MHz to 4050MHz, the tested frequency is the display frequency add 3000MHz.

## AT808 GSM Servicing RF Signal Generator (Optional)

AT 808 Mobile Phone Signal Generator analogs RF signals of receiving frequency range for mobile phones. The unit is mainly used in maintaining failures of mobile receiver, it is regarded as the spectrum analyzer's best partner.

## Functions

Since the phone's receiving signals transmit by base

station are instability, normally between -70dBm to 90dBm, and maybe weaker in some place or even no signal. In order to make it easier to test and analyze the RF circuit (esp. the IF signal) with spectrum analyzer, AT808 RF Signal Generator for mobile phones has been researched by ATTEN, its frequency as well as the output amplitude can be quantitatively adjusted. Therefore, receiving or no receiving problems can be examined by using accompany with AT5010 spectrum analyzer.

AT808 RF Signal Generator combines with spectrum analyzer is very conveniently to repair the receiver parts of mobile phone, if you have some knowledge with the phone's circuit, all failures of mobile phone can be soon repaired by both RF signal generator and spectrum analyzer.

## Features

Output adjustable RF signal between 935MHz to 960MHz, it can be set 3 fixed frequency output by using the buttons. They are 945MHz of Channel 50, 950MHz of Channel 75, 955MHz of Channel 100. AT808 apply advanced imported SMD to insure its high quality and high reliability.

The signal amplitude range of the RF Signal Generator is between -85 to -20dBm, it can be set different amplitude of signal output by pressing the attenuation buttons. In testing phones without signal receiving, usually set the output of signal generator to about -20dBm (*do not press down any attenuation button, and the output amplitude of the unit is -20dBm*). In test the phones weak in receiving, usually set the output of signal generator to about -70dBm (*press three attenuation buttons: 20dB, 20dB and 10dB, and the output amplitude of the unit is -70dBm*).

For Motorola and Nokia, can be set in the testing status, set the signal of receiver to Channel 75 (950 MHz), select the Channel 75 of the unit. ***That is to make the phone's operating channel matches with the channel of AT808 generator, so that the signal of the generator can enter into the phone.***



For other phones, the RF signal can be set in any channel, and required to use with spectrum analyzer.

When connect mobile phone to RF signal generator, just need to connect to the phone's antenna tip via RF cable.

## General Information

The AT5010/5011/5000 spectrum analyzers are easy to operate. The logical arrangement of the controls allows anyone to quickly become familiar with the operation of the instrument, however, experienced users are also advised to read through these instructions so that all functions are understood. Immediately after unpacking, the instrument should be checked for mechanical damage and loose parts in the interior. If there is transport damage, the supplier must be informed immediately. The instrument must then not be put into operation.

## Symbols

-  **ATTENTION** - refer to manual
-  **Danger-High voltage**
-  **Protective ground (earth) terminal**

## Tilt handle

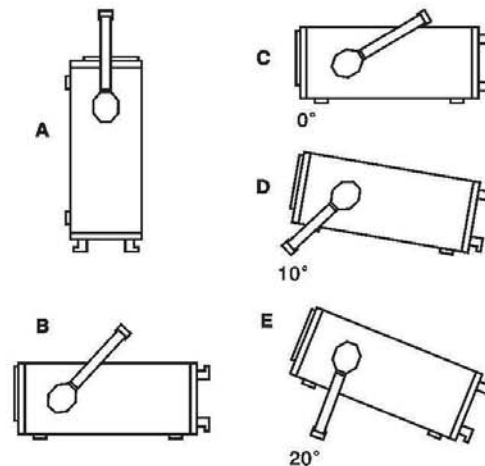

To view the screen from the best angle, there are three different positions (C, D, E) for setting up the instrument. If the instrument is set down on the floor after being carried, the handle automatically remains in the upright carrying position (A). In order to place the instrument onto a horizontal surface, the handle should be turned to the upper side of the Spectrum Analyzer (C). For the D position (10° inclination), the handle should be

---

turned to the opposite direction of the carrying position until it locks in place automatically underneath the instrument. For the E position (20° inclination), the handle should be pulled to release it from the D position and swing backwards until it locks once more. The handle may also be set to a position for horizontal carrying by turning it to the upper side to lock in the B position. At the same time, the instrument must be lifted, because otherwise the handle will jump back.

---

## Safety

This instrument has been designed and tested in accordance with *IEC Publication 1010-1, Safety requirements for electrical equipment for measurement, control, and laboratory use*. The CENELEC regulations EN 61010-1 correspond to this standard. It has left the factory in a safe condition. This instruction manual contains important information and warnings which have to be followed by the user to ensure safe operation and to retain the Spectrum Analyzer in a safe condition. The case, chassis and all measuring terminals are connected to the protective earth contact of the appliance inlet. The instrument operates according to *Safety Class I (three-conductor power cord with protective earthing conductor and a plug with earthing contact)*. The mains/line plug shall only be inserted in a socket outlet provided with a protective earth contact. The protective action must not be negated by the use of an extension cord without a protective conductor. The mains/line plug should be inserted before connections are made to measuring circuits. The grounded accessible metal parts (*case, sockets, jacks*) and the mains/line supply contacts (*line/live, neutral*) of the instrument have been tested against insulation breakdown with 2200V DC. Under certain conditions, 50Hz or 60Hz hum voltages can occur in the measuring circuit due to the interconnection with other mains/line powered equipment or instruments. This can be avoided by using an isolation transformer (*Safety Class II*) between the mains/line outlet and the power plug of the device being investigated. Most cathode-ray tubes develop X-rays. However, *the dose equivalent rate falls far below the maximum permissible value of 36pA/kg (0.5mR/h)*.

Whenever it is likely that protection has been impaired, the instrument shall be made inoperative and be secured against any unintended operation. The protection is likely to be impaired if, for example, the instrument:

- shows visible damage.
- fails to perform the intended measurements.
- has been subjected to prolonged storage under unfavorable conditions (*e. g. in the open or in moist environments*).
- has been subject to severe transport stress (*e. g. in poor packaging*).

---

## Operating conditions

The instrument has been designed for indoor use. The permissible ambient temperature range during operation is +10°C (+50° F) ... +40°C (+104° F). It may occasionally be subjected to temperatures between +10°C (+50° F) and -10°C (+14° F) without degrading its safety. The permissible ambient temperature range for storage or transportation is -40°C (-40° F) ... +70°C (+158° F). The maximum operating altitude is up to 2200m (*non-operating 1500m*). The maximum relative humidity is up to 80%.

If condensed water exists in the instrument it should be acclimatized before switching on. In some cases (*e.g. extremely cold spectrum analyzer*) two hours should be allowed before the instrument is put into operation. The instrument should be kept in a clean and dry room and must not be operated in explosive, dusty, or moist environments. The spectrum analyzer can be operated in any position, but the convection cooling must not be impaired. For continuous operation the instrument should be used in the horizontal position, preferably tilted upwards, resting the tilt handle.

*The specifications stating tolerances are only valid if the instrument has warmed up for 60 minutes at ambient temperature between +15°C (+59° F) and +30°C (+86° F). Values without tolerances are typical for an average instrument.*

## Warranty

ATTEN warrants to its Customers that the products it manufactures and sells will be free from defects in materials and workmanship for a period of 1 years. This warranty shall not apply to any defect, failure or damage caused by improper use or inadequate maintenance and care. ATTEN shall not be obliged to provide service under this warranty to repair damage resulting from attempts by personnel other than ATTEN representatives to install, repair, service or modify these products.

In order to obtain service under this warranty,

Customers must contact and notify the distributor who has sold the product.

Each instrument is subjected to a quality test with 10 hour burn-in before leaving the production. Practically all early failures are detected by this method. In the case of shipments by post, rail or carrier it is recommended that the original packing is carefully preserved. Transport damages and damage due to gross negligence are not cover by the warranty.

In the case of a complaint, a label should be attached to the housing of the instrument which describes briefly the faults observed. If at the same time the name and telephone number (dialing code and telephone or direct number or department designation) is stated for possible queries, this helps towards speeding up the processing of warranty claims.

## Maintenance

Various important properties of the Spectrum Analyzer should be carefully checked at certain intervals. Only in this it largely certain that all signals are displayed with the accuracy on which the technical data are based.

The exterior of the instrument should be cleaned regularly with a dusting brush. Dirt which is difficult to remove on the casing and handle, the plastic and aluminum parts, can be removed with a moistened cloth (*99% water +1% mild detergent*). Spirit or washing benzine (*petroleum ether*) can be used to remove greasy dirt. The screen may be cleaned with water or washing benzene [but not with spirit (*alcohol*) or solvents], it must then be wiped with a dry clean lint-free cloth. Under no circumstances may the cleaning fluid get into the instrument. The use of other cleaning agents can attack the plastic and paint surfaces.

## Switching over the mains/line voltage

The spectrum analyzer operates on mains/line voltages of 115V AC and 230V AC. The voltage selection switch is located on the rear of the instrument and displays the selected voltage can



be selected using a small screwdriver. Remove the power cable from the power connector prior to making any changes to the voltage setting. The fuses must also be replaced with the appropriate value (see table below) prior to connecting the power cable. Both fuses are externally accessible by removing the fuse cover located above the 3-pole power connector.

The fuseholder can be released by pressing its plastic retainers with the aid of a small screwdriver. The retainers are located on the right and left side of the holder and must be pressed towards the center. The fuse(s) can then be replaced and pressed in until locked on both sides.

Use of patched fuses or short-circuiting of the fuseholder is not permissible; ATTEN assumes no liability whatsoever for any damage caused as a result, and all warranty claims become null and void.

## Fuse type

- Size 5×20mm,
- 250-Volt AC,
- Must meet IEC specification 127,
- Sheet III (or DIN 41 662 or DIN 41 571, sheet 3)
- Time characteristic: time-lag

Line voltage: 115V~ ± 10%    Fuse rating: T315mA  
Line voltage: 230V~ ± 10%    Fuse rating: T160mA



## Introduction

The spectrum analyzer permits the detection of spectrum components of electrical signals in the frequency range of 0.15 to 1050MHz. The detected signal and its content have to be repetitive. In contrast to an oscilloscope operated in Yt mode, where the amplitude is displayed on the time domain, the spectrum analyzer displays amplitude on the frequency domain (Yf). The individual spectrum components of "a signal" become visible on a spectrum analyzer. The oscilloscope would display the same signal as one resulting waveform.

The spectrum analyzer works according to the triple superhet receiver principle. The signal to be measured ( $f_{in} = 0.15\text{MHz to } 1050\text{MHz}$ ) is applied to the 1st mixer it is mixed with the signal of a variable voltage controlled oscillator ( $f_{LO} 1350\text{MHz to } 2350\text{MHz}$ ). This oscillator is called the 1st LO (*local oscillator*). The difference between the oscillator and the input frequency ( $f_{LO} f_{in} = 1\text{st IF}$ ) is the first intermediate frequency, which passes through a waveband filter tuned to a center frequency of 1350MHz. It then enters an amplifier, and this is followed by two additional mixing stages, oscillators and amplifiers. The second IF is 29.875MHz and the third is 2.75MHz. In the third IF stage, the signal can be selectively transferred through a filter with 400KHz or 20KHz bandwidth before arriving at an AM demodulator. The logarithmic output (*video signal*) is transferred directly, or via a low pass filter to another amplifier. This amplifier output is connected to the Y deflection plates of the CRT.

The X deflection is performed with a ramp generator voltage. This voltage can also be superimposed on a dc voltage which allows for the control of 1st LO. The spectrum analyzer scans a frequency range depending on the ramp height. This span is determined by the scanwidth setting. In ZERO SCAN mode only the direct voltage controls the 1st LO.

The AT 5011 also includes a tracking generator. This generator provides sine wave voltages within the frequency range of 0.15 to 1050MHz. The tracking generator is determined by the first oscillator (1st LO) of the spectrum analyzer section. Spectrum

analyzer and tracking generator are frequency synchronized.

## Operating Instructions

It is very important to read the paragraph "Safety" including the instructions prior to operating the AT5010/11. No special knowledge is necessary for the operation of the AT5010/11. The straightforward front panel layout and the limitation to basic functions guarantee efficient operation immediately. To ensure optimum operation of the instructions need to be followed.

### Attention!

*The most sensitive component of the AT 5010/ AT 5011 is the input section of the Spectrum Analyzer. It consists of the signal attenuator and the first mixer. Without input attenuation, the voltage at the input must not exceed +10 dB (0.7 Vrms) AC or  $\pm 25$  volt DC. With a maximum input attenuation of 40dB the AC voltage must not exceed +20dBm.*

*These limits must not be exceeded.*

*otherwise the input attenuator and/or the first mixer would be destroyed.*

*When measuring via a LISN (line impedance stabilization network) the input of the Spectrum Analyzer must be protected by means of a transient limiter (Az560)*

Prior to examining unidentified signals, the presence of unacceptable high voltages has to be checked. It is also recommended to start measurements with the highest possible attenuation and a maximum frequency range (1000MHz). The user should also consider the possibility of excessively high signal amplitudes outside the covered frequency range, although not displayed (e.g. 1200MHz). The frequency range of 0Hz 150KHz is not specified for the AT 5010/11 Spectrum Analyzer. Spectral lines within this range would be displayed with incorrect amplitude. A particularly high intensity setting shall be avoided. The way signals are displayed on the spectrum analyzer typically allows for any signal to be recognized easily, even with low intensity.

*Due to the frequency conversion principle, a spectral line is visible at 0Hz. It is called If-feedthrough. The line appears when the 1st LO frequency passes the If amplifiers and filters. The level of this spectral line is different in each instrument. A deviation from the full screen does not indicate a malfunctioning instrument.*

## Control Elements

The front view picture of the instrument (*see last page*) contains numbers referred to below.

### (1) Focus

Beam sharpness adjustment.

### (2) Intens

Beam intensity adjustment.

### (3) Power (Power ON and OFF)

If power is switched to ON position, a beam will be visible on the screen after approximately 10 sec..

### (4) TR (Trace Rotation)

In spite of Mumetal-shielding of the CRT, effects of the earth's magnetic field on horizontal trace position cannot be completely avoided. A potentiometer accessible through an opening can be used for correction. Slight pincushion distortion is unavoidable and cannot be corrected.

### (5) Marker ON/OFF

When the MARKER pushbutton is set to the OFF position, the CF indicator is field on the horizontal. When the switch is in the ON position, MK is lit and the display shows the center frequency. The marker is shown on the screen as a sharp peak. The marker frequency is adjustable by means of the MARKER knob and can be aligned with a spectral line.

*Switch off the marker before taking correct amplitude readings.*

### (6) CF/MK (Center Frequency/Marker)

The CF LED is lit when the digital display shows the center frequency. The center frequency is the frequency which is displayed in the horizontal center of the CRT. The MK LED is lit when the Marker pushbutton is in the ON position. The digital display shows the marker frequency in that case.

---

### (7) Digital Display (Display of Center Frequency / Marker Frequency)

7-segm. Display with 100KHz resolution.

### (8) Uncal

Blinking to this LED indicates incorrectly displayed amplitude values. This is due to scanwidth and filter setting combinations which give to low amplitude readings because the If-filters have not being settled. This may occur when the scanned frequency range (SCANWIDTH) is too large compared to the IF bandwidth (20KHz), and/or the video filter bandwidth (4KHz). Measurements in this case can either be taken without a video filter or the scanwidth has to be decreased.

### (9) Center frequency-Coarse/Fine

Both rotary knobs are used for center frequency setting. The center frequency is displayed at the horizontal center of the screen.

### (10) Bandwidth

Selects between 400KHz and 20KHz IF bandwidth. If a bandwidth of 20KHz is selected, the noise level decreases and the selectivity is improved. Spectral lines which are relatively close together can be distinguished. As the small signal transient response requires a longer time this causes incorrect amplitude values if the scanwidth is set at too wide a frequency span. The UNCAL. LED will indicate this condition.

### (11) Video Filter

The video filter may be used to reduce noise on the screen. It enables small level spectral lines to become visible which normally would be within or just above the medium noise level. The filter bandwidth is 4KHz.

### (12) Y-Position

Control for adjusting the vertical beam position.

### (13) Input

The BNC 50  $\Omega$  input of the Spectrum Analyzer. Without input attenuation the maximum permissible input voltages of  $\pm 25V$  DC and  $+10dBm$  AC must not be exceeded. With the maximum input attenuation of 40dB the maximum input voltage is  $+20dBm$ .

The maximum dynamic range of the instrument is 70dB. Higher input voltages exceeding the reference level cause signal compression and intermodulation. Those effects will lead to erroneous displays. If the input level exceeds the reference level, the input level attenuation must be increased.

---

### (14) Attenuator

The Input Attenuator consists of four 10dB attenuators, reducing the signal height before entering the 1st mixer. Each attenuator is active if the push button is depressed. The correlation of selected attenuation, reference level, and baseline level (*noise level*) is according to the following listing:

Attenuation	Reference level	Base line
0dB	- 27dBm 10mV	- 107dBm
10dB	- 17dBm 31.6mV	- 97dBm
20dB	- 7dBm 0.1V	- 87dBm
30dB	+ 3dBm 316mV	- 77dBm
40dB	+ 13dBm 1V	- 67dBm

The reference level is represented by the upper horizontal graticule line. The lowest horizontal graticule line indicates the baseline. The vertical graticule is subdivided in 10dB steps. As previously pointed out, the maximum permissible input voltages may not be exceeded. This is extremely important because it is possible that the Spectrum Analyzer will only show a partial spectrum of currently applied signals. Consequently, input signals might be applied with excessive levels outside the displayed frequency range leading to the destruction of the input attenuator and/or the 1st mixing stage. Also refer to INPUT.

The highest attenuation ( $4 \times 10dB$ ) and the highest usable frequency range (scanwidth setting 50MHz/DIV.) should be selected prior to any spectral to the AT5010/11 input. This permits the detection of any spectral lines which are within the maximum measurable and displayable frequency range if the center frequency is set to 500MHz. If the baseline tends to move upwards upwards when the attenuation is decreased, it may indicate spectral lines outside the maximum displayable frequency range (i.e.1200MHz) with excessive amplitude.

### (15) Scanwidth <> (Push buttons)

The SCANWIDTH selectors allow to control the scanwidth per division of the horizontal axis. The frequency/Div. can be increased by means of the > button, and decreased by means of the < button. Switching is accomplished in 1-2-5 steps from 100KHz/div. to 100KHz/div. The width of the scan range is displayed in MHz/div. and refers to each horizontal division on the graticule. The center

frequency is indicated by the vertical graticule line at middle of the horizontal axis. If the center frequency and the scanwidth settings are correct, the X axis has a length of 10 divisions. On scanwidth settings lower than 100MHz, only a part of the entire frequency range is displayed. When SCANWIDTH is set to 100MHz/div. and if center frequency is set to 500MHz, the displayed frequency range extends to the right by 100MHz per division, ending at 1000MHz [500MHz+(5×100MHz)]. The frequency decreases to decreases to the left in a similar way. In this case the left graticule line corresponds to 0Hz. With these settings, a spectral line is visible which is referred to as "Zero Frequency". It is the 1st LO (oscillator) which becomes visible when its frequency passes the first IF filter, This occurs when the center frequency is low relative to the scanwidth range selected. The "Zero Frequency" is different in level in every instrument and therefore cannot be used as a reference level. Spectral lines displayed left of the "Zero Frequency Point" are so-called image frequencies. In the ZERO SCAN mode the Spectrum Analyzer operates like Spectral line(s) passing the IF filter cause a level display (selective voltmeter function).

The selected scanwidth/div. settings are indicated by a number of LEDs above the range setting push buttons.

**(16) X-POS.** (X-position)

**(17) X-AMPL.** (X-amplitude)

### **Important:**

*These controls are only necessary when calibrating the instrument. They do not require adjustment under normal operating conditions. A very accurate RF Generator (e.g. ATTEN AT8133) is necessary if any adjustment of these controls is required.*

### **(18) Phone**

(3.5mm earphone connector)

An earphone or loudspeaker with an impedance > 16Ω can be connected to this output. When tuning the Spectrum Analyzer to a spectral line possibly available audio signals can be detected. The signal is provided by an AM-Demodulator in the IF-section. It demodulates any available AM-Signal and provides as well one-side

FM-Demodulation. The output is short circuit proof.

### **(19) Volume**

Volume setting for earphone output.

### **(20) Probe Power**

The output provides a +6Vdc voltage for the operation of an AZ530 near field sniffer probe. It is only provided for this purpose and requires a special cable which is shipped along with the AZ530 probe set.

### **(21) Level (AT5011 only)**

The output level of the Tracking can be continuously adjusted with this knob by 11dBm (-10dB to +1dBm).

### **(22) TRACK. GEN . (AT5011 only)**

The Tracking Generator is activated if the push button is depressed (ON). In this case, a sine signal can be obtained from the OUTPUT BNC socket with a frequency determined by the Spectrum Analyzer. In ZERO SCAN mode the Center Frequency appears at the output.

### **(23) Output (AT5011 only)**

50 Ω BNC socket of the Tracking Generator. The output level can be determined from +1dBm to -50dBm.

### **(24) attention (AT5011 only)**

Output level attenuator with four 10dB attenuators which allows the signal to be reduced prior to reaching the OUTPUT socket.

All four attenuators are equal and can be activated by pressing the respective push button. Therefore, it is irrelevant which attenuators are used to reach e.g. a 20dB attenuation.

## **Vertical Calibration**

*Ensure all input attenuators in released position before calibration. When the signal amplitude reaches to the highest level-line, the signal amplitude is -27dBm, and it will reduce 10dBm for each division drop. If the 40dB attenuator in the spectrum analyzer is completely pressed down, the highest level amplitude will be +13dBm (-27dBm+40dBm).*

Prior to calibration, ensure that all input attenuators (14) are released. The AT5010/11 must be in operation for at least 60 minutes prior to calibration. Switch VIDEO FILTER (11) to OFF position, set

---

BANDWIDTH (10) to 400KHz, and SCANWIDTH (15) to 2MHz/div.

Connect RF signal of  $-27\text{dBm} \pm 0.2\text{dB}$  (10mV) to the spectrum analyzer input (13). The frequency of this signal should be between 2MHz and 250MHz. Set the center frequency to the signal frequency.

**A:** A single spectral line ( $-27\text{dBm}$ ) appears on the screen. The spectral line maximum is now adjusted with the Y-POS. control (12) and placed at the top graticule line of the screen. All input attenuators switches have to be released.

The following adjustment is only necessary for service purposes and if the check of this setting shows deviations of the correct settings. The Y-ampl. Control is located on the XY-PCB inside the instrument. In case any adjustment of the vertical amplification is necessary, please refer to the service manual.

**B:** Next, the generator signal must be switched back and forth between  $-27\text{dBm}$  and  $-77\text{dBm}$ , and the Y-AMPL. Control adjusted so that the spectral line peak changes by 5 divisions in the vertical direction. If this results in a change of the Y-position, the calibration outlined under A and B have to be repeated until an ideal adjustment is achieved. Finally, the operation of the input attenuators (14) can be tested at a level of  $-27\text{dBm}$ . The spectral line visible on the screen can be reduced in 4 steps of 10dB each by activating the attenuators incorporated in the spectrum analyzer. Each 10dB step corresponds to one graticule division on the screen. The tolerance may not exceed  $\pm 1\text{dB}$  in all attenuation positions.

---

**C:** Set generator frequency to 500MHz. Adjust the peak of the 500MHz spectral line to the horizontal screen center using the X-POS. control (16).

**D:** Set the generator frequency to 100MHz. If the 100MHz spectral line is not on the 2nd. graticule line from left, it should be aligned using the X-AMPL. Control (17). Then the calibration as de-scribed under be verified and corrected if necessary. The calibrations C and D should be repeated until optimum adjustment is achieved.

## Horizontal Calibration

Prior to calibration ensure that all input attenuator switches (14) are released. The AT5010/11 must be operated for at least 60 minutes prior to calibration. The VIDEO FILTER push button (11) must be in OFF position, the BANDWIDTH (10) must be set to 400KHz, and SCANWIDTH (15) set to 100KHz/div. After the center frequency is set to 500MHz, a generator signal must be applied to the input. The output level should level should be between 40 and 50 dB above the noise.



---

# Introduction to Spectrum Analysis

The analysis of electrical signals is a fundamental problem for many engineers and scientists. Even if the immediate problem is not electrical, the basic parameters of interest are often changed into electrical signals by means of transducers. The rewards for transforming physical parameters to electrical signals are great, as many instruments are available for the analysis of electrical signals in the time and frequency domains.

The traditional way of observing electrical signals is to view them in the time domain using an oscilloscope. The time domain is used to recover relative timing and phase information which is needed to characterize electric circuit behavior. However, not all circuits can be uniquely characterized from just time domain information. Circuit elements such as amplifiers, oscillators, mixers, modulators, detectors and filters are best characterized by their frequency response information. This frequency information is best obtained by viewing electrical signals in the frequency domain. To display the frequency domain requires a device that can discriminate between frequencies while measuring the power level at each. One instrument which displays the frequency domain is the spectrum analyzer. It graphically displays voltage or power as a function of frequency only on a CRT (*cathode ray tube*).

In the time domain, frequency components of a signal are seen summed together. In the frequency domain, complex signals (*i.e. signals composed of more than one frequency*) are separated into their frequency components, and the power level at each frequency is displayed. The frequency domain is a graphical representation of signal amplitude as a function of frequency. The frequency domain contains information not found in the time domain and therefore, the spectrum analyzer has certain advantages compared with an oscilloscope.

The analyzer is more sensitive to low level distortion than a scope. Sine waves may look in the time domain, but in the frequency domain, harmonic distortion can be seen. The sensitivity and wide

---

dynamic range of the spectrum analyzer is useful for measuring low-level modulation. It can be used to measure AM, FM and pulsed RF. The analyzer can be used to measure carrier frequency, modulation frequency, modulation level, and modulation distortion. Frequency conversion devices can be easily characterized. Such parameters as conversion loss, isolation, and distortion are readily determined from the display.

The spectrum analyzer can be used to measure long and short term stability. Parameters such as noise sidebands on an oscillator, residual FM of a source and frequency drift during warm-up can be measured using the spectrum analyzer's calibrated scans. The swept frequency responses of a filter or amplifier are examples of swept frequency measurements possible with a spectrum analyzer. These measurements are simplified by using a tracking generator.

## Types of Spectrum Analyzers

There are two basic types of spectrum analyzers, swept-tuned and real-time analyzers. The swept-tuned analyzers are tuned by electrically sweeping them over their frequency range. Therefore, the frequency components of a spectrum are sampled sequentially in time. This enables periodic and random signals to be displayed, but makes it impossible to display transient responses. Real-time analyzers, on the other hand, simultaneously display the amplitude of all signals in the frequency range of the analyzer; hence the name real-time. This preserves the time dependency between signals which permits phase information to be displayed. Real-time analyzers are capable of displaying transient responses as well as periodic and random signals.

The swept-tuned analyzers of the *trf* (*tuned radio frequency*) or superheterodyne type. A *trf* analyzer consists of a bandpass filter whose center frequency is tunable over a desired frequency range, a detector to produce vertical deflection on a CRT, and a horizontal scan generator used to synchronize the tuned frequency to the CRT horizontal deflection. It is a simple, inexpensive analyzer with wide frequency coverage, but lacks resolution and

---

sensitivity. Because trf analyzers have a swept filter they are limited in sweep width depending on the frequency range (*usually one decade or less*). The resolution is determined by the filter bandwidth, and since tunable filters don't usually have constant bandwidth, is dependent on frequency.

The most common type of spectrum analyzer differs from the trf spectrum analyzers in that the spectrum is swept through a fixed bandpass filter instead of sweeping the filter through the spectrum. The analyzer is swept through a narrowband receiver which is electronically tuned in frequency by applying a saw-tooth voltage to the frequency control element of a voltage tuned local oscillator. This same saw-tooth voltage is simultaneously applied to the horizontal deflection plates of the CRT. The output from the receiver is synchronously applied to the vertical deflection plates of the CRT and a plot of amplitude versus frequency is displayed.

The analyzer is tuned through its frequency range by varying the voltage on the LO (*local oscillator*). The LO frequency is mixed with the input signal to produce an IF (*intermediate frequency*) which can be detected and displayed. When the frequency difference between the input signal and the LO frequency is equal to the IF frequency, then there is a response on the analyzer. The advantages of the superheterodyne technique are considerable. It obtains high sensitivity through the use of IF amplifiers, and many decades in frequency can be tuned.

Also, the resolution can be varied by changing the bandwidth of the IF filters. However, the superheterodyne analyzer is not real-time and sweep rates must be consistent with the IF filter time constant. A peak at the left edge of the CRT is sometimes called the "zero frequency indicator" or "local oscillator feedthrough". It occurs when the analyzer is tuned to zero frequency, and the local oscillator passes directly through IF creating a peak on the CRT even when no input signal is present. (*For zero frequency tuning, FLO=FIF*). This effectively limits the lower tuning limit.

---

## Spectrum Analyzer Requirements

To accurately display the frequency and amplitude of a signal on a spectrum analyzer, the analyzer itself must be properly calibrated. A spectrum analyzer properly designed for accurate frequency and amplitude measurements has to satisfy many requirements:

- Wide tuning range
- Wide frequency display range
- Stability
- Resolution
- Flat frequency response
- High sensitivity
- Low internal distortion

---

## Frequency Measurements

The frequency scale can be scanned in three different modes full, per division, and zero scan. The full scan mode is used to locate signals because the widest frequency ranges are displayed in this mode. (*Not all spectrum analyzers offer this mode*). The per division mode is used to zoom-in on a particular signal. In per division, the center frequency of the display is set by the Tuning control and the scale factor is set by the Frequency Span or Scan Width control. In the zero scan mode, the analyzer acts as a fixed-tuned receiver with selectable bandwidths.

Absolute frequency measurements are usually made from the spectrum analyzer tuning dial. Relative frequency measurements require a linear frequency scan. By measuring the relative separation of two signals on the display, the frequency difference can be determined.

It is important that the spectrum analyzer be more stable than the signals being measured. The stability of the analyzer depends on the frequency stability of its local oscillators. Stability is usually characterized as either short term or long term. Residual FM is a measure of the short term stability which is usually specified in Hz peak-to-peak. Short term stability is also characterized by noise sidebands which are a measure of the analyzers spectral purity. Noise sidebands are specified in terms of dB down and Hz away from a carrier in a specific bandwidth. Long term stability is

---

characterized by the frequency drift of the analyzers. Frequency drift is a measure of how much the frequency changes during a specified time (*i.e.*, Hz/hr)

## Resolution

Before the frequency of a signal can be measured on a spectrum analyzer it must first be re-solved. Resolving a signal means distinguishing it from its nearest neighbors. The resolution of a spectrum analyzer is determined by its IF bandwidth. The IF bandwidth is usually the 3dB bandwidth of the IF filter. The ratio of the 60dB bandwidth (in Hz) to the 3dB bandwidth (in Hz) is known as the shape factor of the filter. The smaller the shape factor, the greater is the analyzer's capability to resolve closely spaced signals of unequal amplitude. If the shape factor of a filter is 15:, then two signals whose amplitudes differ by 60dB must differ in frequency by 7.5 times the IF bandwidth before they can be distinguished separately. Otherwise, they will appear as one signal on the spectrum analyzer display.

The ability of a spectrum analyzer to resolve closely spaced signals of unequal amplitude is not a function of the IF filter shape factor only. Noise sidebands can also reduce the resolution. They appear above the skirt of the IF filter and reduce the offband rejection of the filter. This limits the resolution when measuring signals of unequal amplitude.

The resolution of the spectrum analyzer is limited by its narrowest IF bandwidth. For example, if the narrowest bandwidth is 10KHz then the nearest any two signals can be and still be resolved is 10KHz. This is because the analyzer traces out its own IF band-pass shape as it sweeps through a CW signal. Since the resolution of the analyzer is limited by bandwidth, it seems that by reducing the IF bandwidth infinitely, infinite resolution will be achieved. The fallacy here is that the usable IF bandwidth is limited by the stability (*residual Fm*) of the analyzer. If the internal frequency deviation of the analyzer is 10KHz, then the narrowest bandwidth that can be used to distinguish a single input signal is 10KHz. Any narrower IF-filter will result in more than one response or an intermittent

---

response for a single input frequency. A practical limitation exists on the IF bandwidth as well, since narrow filters have long time constants and would require excessive scan time.

## Sensitivity

Sensitivity is a measure of the analyzer's ability to detect small signals. The maximum sensitivity of an analyzer is limited by its internally generated noise. The noise is basically of two types: thermal (*or Johnson*) and nonthermal noise. Thermal noise power can be expressed as:

$$P_n = K \cdot T \cdot B$$

Where:

$P_n$  = Noise power in watts

$K$  = Boltzmann's Constant ( $1.38 \times 10^{-23}$  Joule/K)

$T$  = absolute temperature, K

$B$  = bandwidth of system in Hertz

As seen from this equation, the noise level is directly proportional to bandwidth. Therefore, a decade decrease in bandwidth results in a 10dB decrease in noise level and consequently 10dB better sensitivity. Nonthermal noise accounts for all noise produced within the analyzer that is not temperature dependent. Spurious emissions due to nonlinearities of active elements, impedance mismatch, etc. are sources of nonthermal noise. A figure of merit, or noise figure, is usually assigned to this nonthermal noise which when added to the thermal noise gives the total noise of the analyzer system. This system noise which is measured on the CRT, determines the maximum sensitivity of the spectrum analyzer. Because noise level changes with bandwidth it is important, when comparing the sensitivity of two analyzers, to compare sensitivity specifications for equal bandwidths. A spectrum analyzer sweeps over a wide frequency range, but is really a narrow band instrument. All of the signals that appear in the frequency range of the analyzer are converted to a single IF frequency which must pass through an IF filter; the detector sees only this noise at any time. Therefore, the noise displayed on the analyzer is only that which is contained in the IF passband. When measuring discrete signals, maximum sensitivity is obtained by using the narrowest IF bandwidth.

---

## Video Filtering

Measuring small signals can be difficult when they are approximately the same amplitude as the average internal noise level of the analyzer. To facilitate the measurement, it is best to use video filtering. A video filter is a post-detection low pass filter which averages the internal noise of the analyzer. When the noise is averaged, the input signal may be seen. If the resolution bandwidth is very narrow for the span, the span, the video filter should not be selected, as this will not allow the amplitude of the analyzed signals to reach full amplitude due to its video bandwidth limiting property.

## Spectrum Analyzer Sensitivity

Specifying sensitivity on a spectrum analyzer is somewhat arbitrary. One way of specifying sensitivity is to define it as the signal level when signal power = average noise power. The analyzer always measures signal plus noise. Therefore, when the input signal is equal to the internal noise level, the signal will appear 3dB above the noise. When the signal power is added to the average noise power, the power level on the CRT is doubled (*increased by 3dB*) because the signal power=average noise power.

The maximum input level to the spectrum analyzer is the damage level or burn-out level of the input circuit. This is (for the AT5010/11) +10dB for the input mixer and +20dB for the input attenuator. Before reaching the damage level of the analyzer, the analyzer will begin to gain compress the input signal. This gain compression is not considered serious until it reaches 1dB. The maximum input signal level which will always result in less than 1dB gain compression is called the linear input level. Above 1dB gain compression the analyzer is considered to be operating nonlinearly because the signal amplitude displayed in the CRT is not an accurate measure of the input signal level.

Whenever a signal is applied to the input of the analyzer, distortions are produced within the analyzer itself. Most of these are caused by the non-linear behavior of the input mixer. For the

AT5010/11 these distortions are typically 70dB below the input signal level for signal levels not exceeding -27dBm at the input of the first mixer. To accommodate larger input signal levels, an attenuator is placed in the input circuit before the first mixer. The largest input signal that can be applied, at each setting of the input attenuator, while maintaining the internally generated distortions below a certain level, is called the optimum input level of the analyzer. The signal is attenuated before the first mixer because the input to the mixer must not exceed -27dB, or the analyzer distortion products may exceed the specified 70dB range. This 70dB distortion-free range is called the spurious-free dynamic range of the analyzer. The display dynamic range is defined as the ratio of the largest signal to the smallest signal that can be displayed simultaneously with no analyzer distortions present.

Dynamic range requires several things then. The display range must be adequate, no spurious or unidentified response can occur, and the sensitivity must be sufficient to eliminate noise from the displayed amplitude range.

The maximum dynamic range for a spectrum analyzer can be easily determined from its specifications. First check the distortion spec. For example, this might be "all spurious products 70dB down for -27dBm at the input mixer". Then, determine that adequate sensitivity exists. For example, 70dB down from -27dBm is -97dB. This is the level we must be able to detect, and the bandwidth required for this sensitivity must not be too narrow or it will be useless. Last, the display range must be adequate.

Notice that the spurious-free measurement range can be extended by reducing the level at the input mixer. The only limitation, then, is sensitivity. To ensure a maximum dynamic range on the CRT display, check to see that the following requirements are satisfied.

- The largest input signal does not exceed the optimum input level of the analyzer (typically -27dBm with 0dB input attenuation).
- The peak of the largest input signal rests at the top of the top of the CRT display (reference level).



---

## Frequency Response

The frequency response of an analyzer is the amplitude linearity of the analyzer over its frequency range. If a spectrum analyzer is to display equal amplitudes for input signals of equal amplitude, independent of frequency, then the conversion (power) loss of the input mixer must not depend on frequency. If the voltage from the LO is too large compared to the input signal voltage then the conversion loss of the input mixer is frequency dependent and the frequency response of the system is nonlinear. For accurate amplitude measurements, a spectrum analyzer should be as flat as possible over its frequency range. Flatness is usually the limiting factor in amplitude accuracy since it is extremely difficult to calibrate out. And, since the primary function of the spectrum analyzer is to compare signal levels at different frequencies, a lack of flatness can seriously limit its usefulness.

## Tracking Generators

The tracking generator (AT5010 only) is a special signal source whose RF output frequency tracks (follows) some other signal beyond the tracking generator itself. In conjunction with the spectrum analyzer, the tracking generator produces a signal whose frequency precisely tracks the spectrum analyzer's tuning. The tracking generator frequency precisely tracks the spectrum analyzer tuning since both are effectively tuned by the same VTO. This precision tracking exists in all analyzer scan modes. Thus, in full scan, the tracking generator output is a start-stop sweep, in zero scan the output is simply a CW signal.

The tracking generator signal is generated by synthesizing and mixing two oscillators. One oscillator is part of the tracking generator itself, the other oscillator is the spectrum analyzer's 1st LO. The spectrum analyzer/tracking generator system is used in two configurations: open-loop and closed-loop. In the open-loop configuration, unknown external signals are connected to the spectrum analyzer input and the tracking generator output is connected to a counter. This configuration is used for making selective and sensitive precise measurement of frequency, by tuning to the signal and switching

to zero scan.

In the closed-loop configuration, the tracking generator signal is fed into the device under test and the output of the device under test is connected to the analyzer input.

In this configuration, the spectrum analyzer/tracking generator becomes a self-contained, complete (source, detector, and display) swept frequency measurement system. An internal leveling loop in the tracking generator ensures a leveled output over the entire frequency range. The specific swept measurements that can be made with this system are frequency response (amplitude vs. frequency), magnitude only reflection coefficient, and return loss. From return loss or reflection coefficient, the SWR can be calculated. Swept phase and group delay measurements cannot be made with this system; however, it does make some unique contributions not made by other swept systems, such as a sweeper/network analyzer, a sweeper/spectrum analyzer, or a sweeper/detector oscilloscope.

Precision tracking means at every instant of time the generator fundamental frequency is in the center of the analyzer passband, and all generator harmonics, whether they are generated in the analyzer or are produced in the tracking generator itself, are outside the analyzer passband. Thus only the tracking generator fundamental frequency is displayed on the analyzer's CRT. Second and third order harmonics and intermodulation products are clearly out of the analyzer's CRT. Second and third order harmonics and intermodulation products are clearly out of the analyzer tuning and, therefore, they are not seen. Thus, while these distortion products may exist in the measurement set-up, they are completely eliminated from the CRT display.

The 1dB gain compression level is a point of convenience, but it is nonetheless considered the upper limit of the dynamic range. The lower limit, on the other hand, is dictated by the analyzer sensitivity which, as we know, is bandwidth dependent. The narrowest usable bandwidth in turn is limited by the tracking generator residual FM and any tracking drift between the analyzer tuning and the tracking generator signal.



---

# Mainly Performance and Calibration of AT5010/5011 Series Spectrum Analyzer

## 1. Structural integrity

No obvious impairment and gilding damage, all outside components are well installation, reliable fasten and flexible operability. Warm up for one hour to inspect the performances.

## 2. Inspection of Y-POS

Adjust Y-POS knob, occurs hand feeling by obvious locating point. *Failures in adjusting the locating point will lead to all measured amplitudes are invalid.*

## 3. Accuracy of frequency readout

Not exceed  $\pm 2\%$  spectrum width +100kHz

## 4. Inspection of frequency range

Output 0.15MHz 1050MHz frequency signal from a signal generator, screen should display the complete signals.

**inspect frequency range of tracking signal generator:** connect output port with frequency counter, both output attenuation and bandwidth are zero, adjust CF knob, to check the signal generator could output 0.15MHz 1050MHz signal or not.

## 5. Inspection of reference level

$\pm 2\text{dB}$  at 500MHz

Output 500MHz frequency and -27dBm level signal, from signal generator to spectrum analyzer. Set spectrum analyzer CF at 500MHz, scanwidth 2MHz/DIV, center frequency 400kHz, with zero input attenuation. And signal amplitude should up to top line.

**Inspect the output level of tracking generator:** connect input to output with a coaxial cable, with CF 500MHz, scanwidth 0MHz/DIV, input attenuation 30dB, maximum output, then amplitude should lower the top line than one graticule.

## 6. Frequency Response

It means signal response of spectrum analyzer in measuring equal level and different frequency. Since the primary function of the spectrum analyzer is to compare signal levels at different frequencies, *a lack of flatness can seriously limit its usefulness.*

---

## 7. Inspection of attenuators

(0~40dB) $4 \times 10\text{dB}$  step,  $\pm 1\text{dB}/10\text{dB}$ ,  $\pm 2\text{dB}(40\text{dB})$ .

## 8. Residual response

### and interference immunity

Short circuit the input by connect a  $50\ \Omega$  terminal load to input port, then signal response should not appears in screen. *Otherwise, it may seriously affect the ability of spectrum analyzer in analyzing small signals.*

Replace the  $50\ \Omega$  terminal load off input port, noise base line should not raise, especially the tracking source cannot affect the instrument. In a common room, no signal response appears in screen.

## 9. Inspection of sensibility

Sensibility should better than -95dB.

Output a -95dBm signal with a standard signal generator, set CF in the frequency, with IF 20kHz, 0.1MHz/DIV scanwidth, video filter on. Spectrum analyzer is able to measure the signal.

## 10. Grass level

The typical value is 15dB when IF bandwidth is 400kHz, otherwise, the sensibility of he unit is too inferior to analyze smaller signals.

# Block Diagram AT5010/11

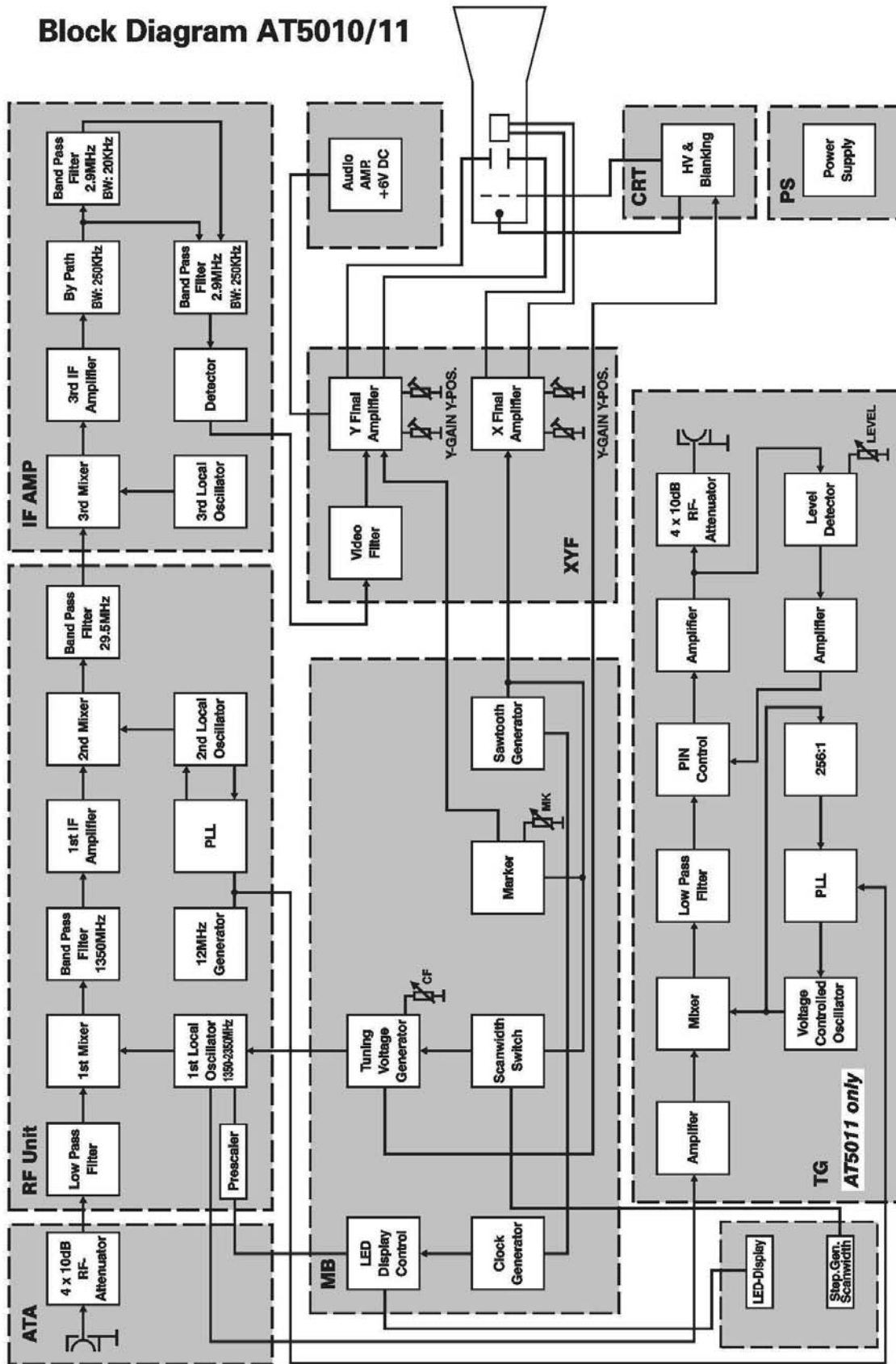

# Front View AT5010

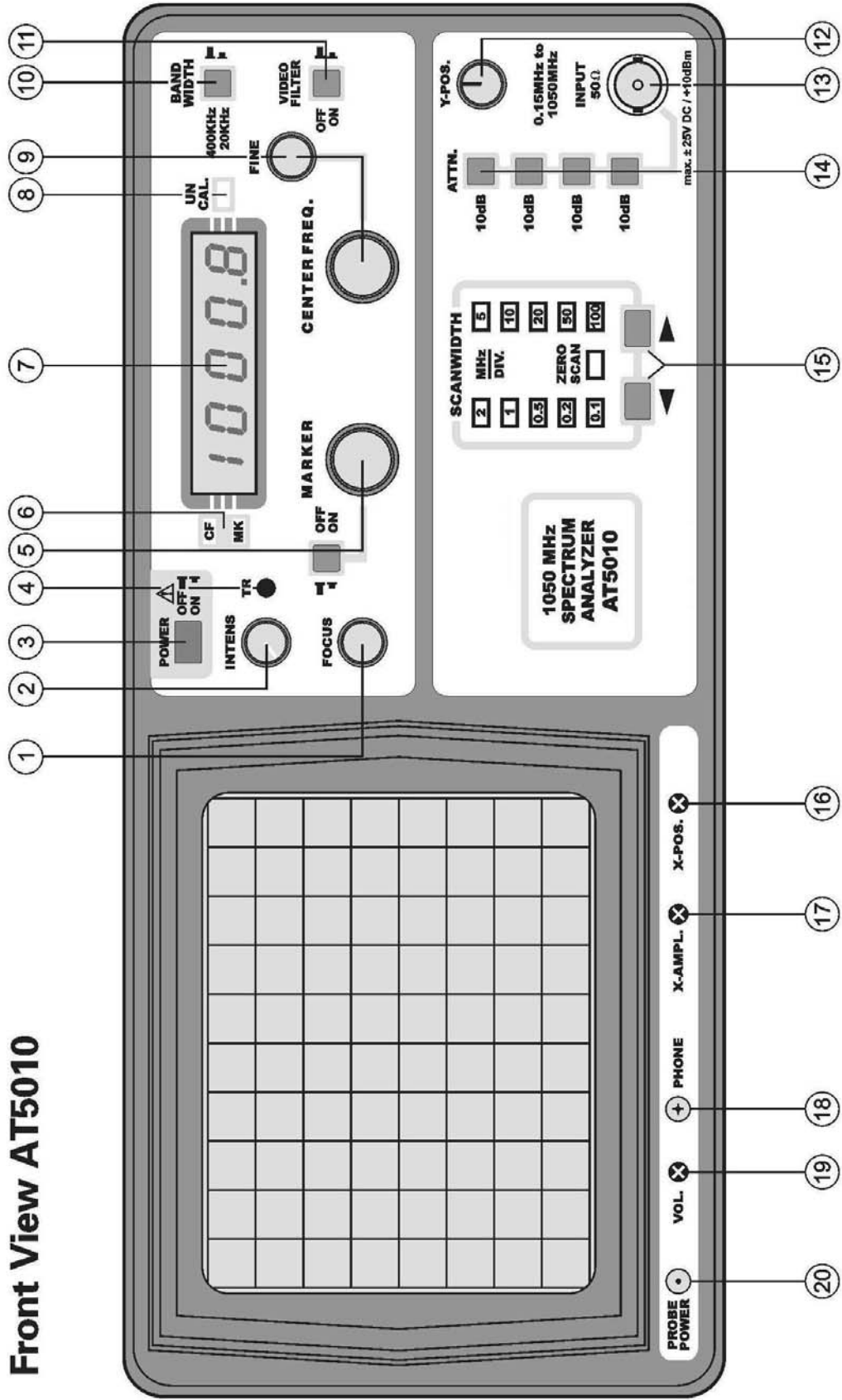

# Front View AT5011

